

English



PRACTICAL GUIDE COMEX 2023

www.joelini.com.br

Superimposed

JP360

+

GUIDA UNIVERSAL FOLGAZERO

DIFERENTIALS - GFZ UNIVERSAL

- SILENT AND SAFE
- NO NEED TO USE WRENCHES AND ADJUSTMENTS
- ASSEMBLY MORE PRATICAL
- FOR ALUMINUM AND WOODEN DOORS
- OPTIONS FOR RAILS OF:
26mm, 28mm , 30mm, 32mm, 34mm,
36mm, 38mm Y 40mm.

SINGLE GUIDE

ALL SIZES OF RAIL

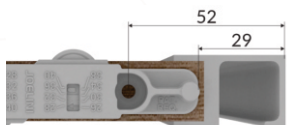
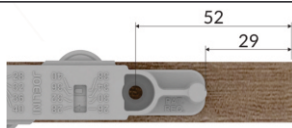

MEASURES ACHIEVED

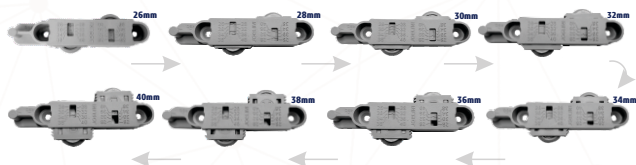

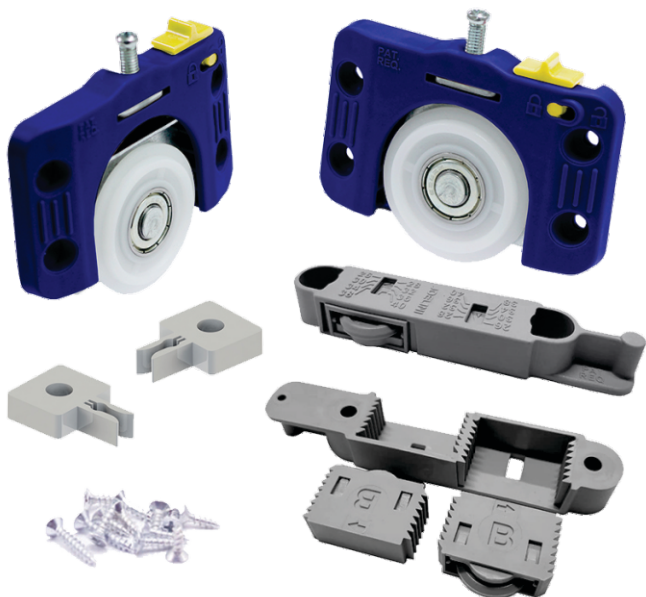



DIFERENTIALS - JP360

- 40MM WHEEL WHIT BEARING
- ARMORED MECHANISM
- REINFORCED ADJUSTMENT SCREW
- RELEASE LOCK
- SUPPORT EDGE
- FOR DOORS TO 60Kg

VARIATIONS

GUIDE	RAIL	IMAGE
Folgazero	27mm a 33,5mm	
DAMPER Folgazero	27mm a 33,5mm	

RECOMMENDATIONS

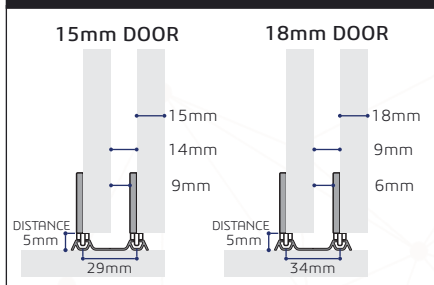

BACK VIEW

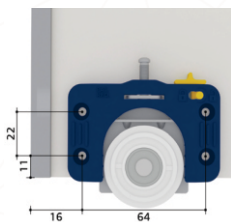

SUPERIMPOSED

JM135 + GMG 2,5mm



DIFERENTIALS

- SUPERIMPOSED SYSTEM
- FOR DOORS UP TO 45kg
- SUPPORT EDGE
- WHELL DIAMETER 33mm

ASSEMBLED



RECOMMENDATIONS

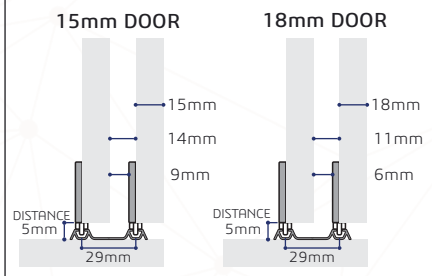

SUPERIMPOSED

JM443

+

GUIA UNIVERSAL

FOLGAZERO

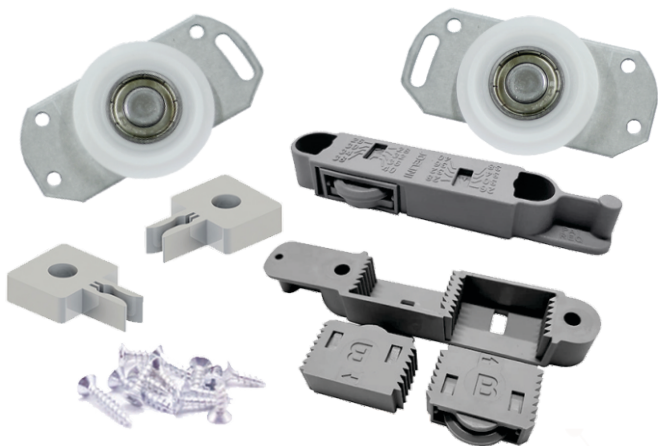

DIFERENTIALS

- SUPERIMPOSED SYSTEM
- FOR WHEELS UP TO 45kg
- WITH BEARING
- WHEEL DIAMETER 41mm

RECOMMENDATIONS

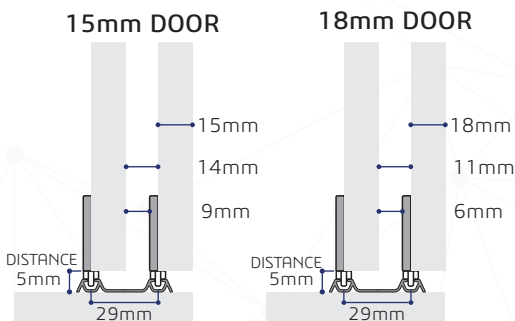

SUPERIMPOSED JP240 + GUIA UNIVERSAL FOLGAZERO



DIFERENTIALS - GFZ UNIVERSAL

- SILENT AND SAFE
- NO NEED TO USE WRENCHES AND ADJUSTMENTS
- ASSEMBLY MORE PRATICAL
- FOR ALIMINUM AND WOODEN DOORS
- OPTIONS FOR RAILS OF:
26mm, 28mm , 30mm, 32mm, 34mm,
36mm, 38mm Y 40mm.

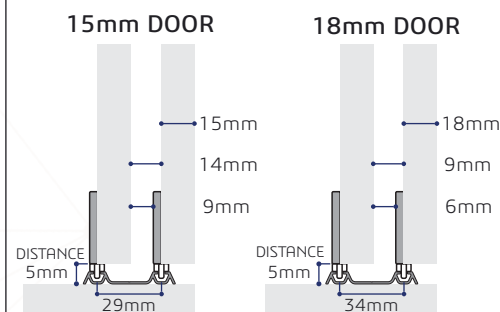
RECOMENDATIONS



VARIATIONS

GUIDE	RAIL	IMAGE
Folgazero	27mm a 33,5mm	
Damper Folgazero	27mm a 33,5mm	



BACK VIEW

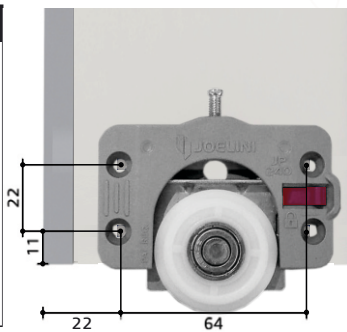

DIFERENTIALS - JP240

- 40mm WHEEL WITH BEARING
- ARMORED MECHANISM
- REINFORCED ADJUSTMENT SCREW
- RELEASE LOCK
- SUPORT EDGE
- FOR DOORS UP TO 50Kg

Sliding door systems

JP55

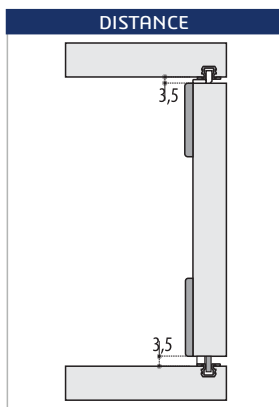

DIFERENTIALS

- BUILT-IN
- EXCELLENT COST BENEFIT
- FOR DOORS UP TO 10KG
- ADJUSTMENT SCREW
- IDEAL FOR SHELVES AND BATHROOM CABINETS

SUPERIMPOSED SYSTEM

JP25



DIFERENTIALS

- SUPERIMPOSED SYSTEM
- WHEELS WITH BEARING
- FOR DOORS UP TO 30Kg
- MAX THICKNESS FROM DOOR 15mm A 20mm
- SUPORT EDGE
- ADJUSTMENT SCREW

DOOR HEIGHT CALCULATION

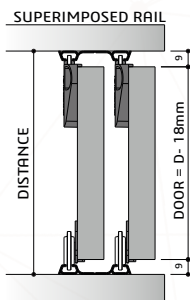
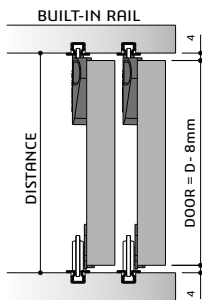

RECOMMENDED DOOR THICKNESS. RAIL AND DISTANCE

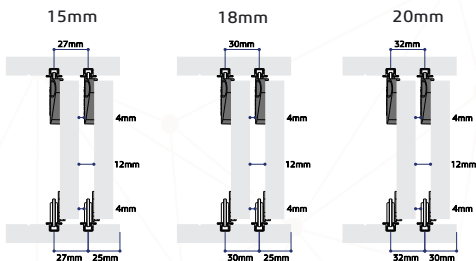

BARN DOOR SYSTEM

JP700

DEFERENTIALS

- 25mm WHEEL WITH BEARING
- CONCAVE OR CONVEX WHEEL
- REINFORCED ADJUSTMENT SCREW
- FOR DOORS UP TO 100kg
- TOP OR SIDE SUPPORT
- (OPTIONAL) JOELINI RAIL COVER



SUPPORT
100 kg



REINFORCED
ADJUSTMENT
SCREW



CONCAVE OR
CONVEX
WHEEL



SUPPORT



LATERAL SUPPORT

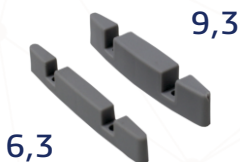

6,3

9,3



13



CONVEX SYSTEM

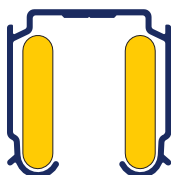

(OPTIONAL)
JOELINI RAIL COVER



CONCAVE SYSTEM

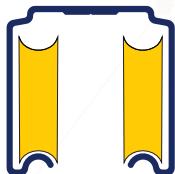



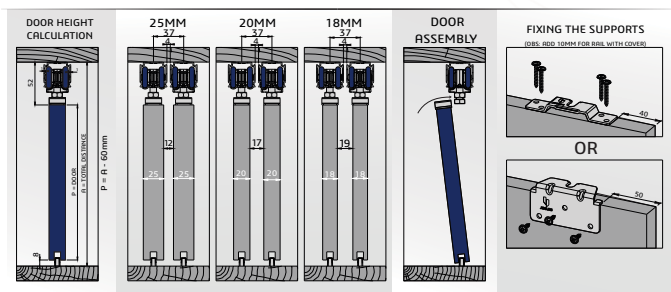

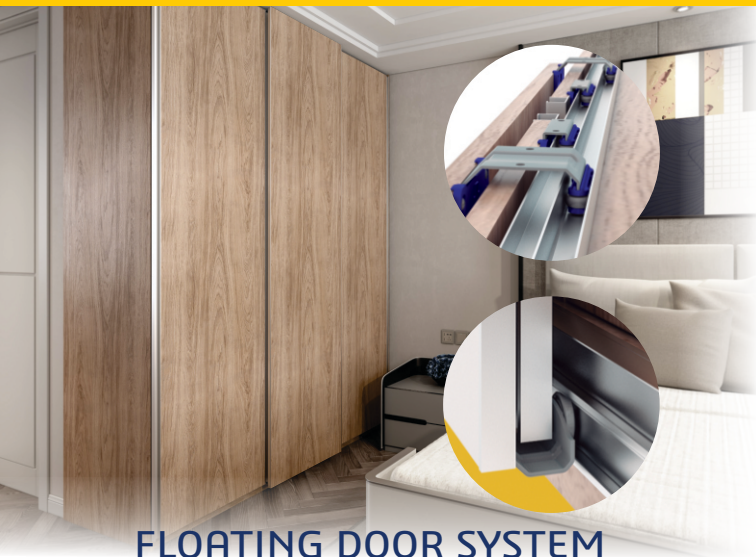
(OPTIONAL)
JOELINI RAIL COVER





FLOATING DOOR SYSTEM AZURE

EASY DOOR DISASSEMBLY

 <p>50kg FOR DOORS UP TO 50KG</p>	 <p>EASY ASSEMBLY</p>
 <p>INVISIBLE SYSTEM: ILLUSION OF FLOATING DOORS</p>	 <p>STEEL SYSTEM</p>
 <p>BEST COST BENEFIT FOR SUPERIMPOSED DOORS</p>	

DIFERENTIALS

- WEIGHT OF THE DOOR SUPPORTED ON THE BASE
- SYSTEM FOR TWO AND THREE DOORS
- ROBUSTNESS AND ECONOMIC
- 100% ANTI-DERRAIL

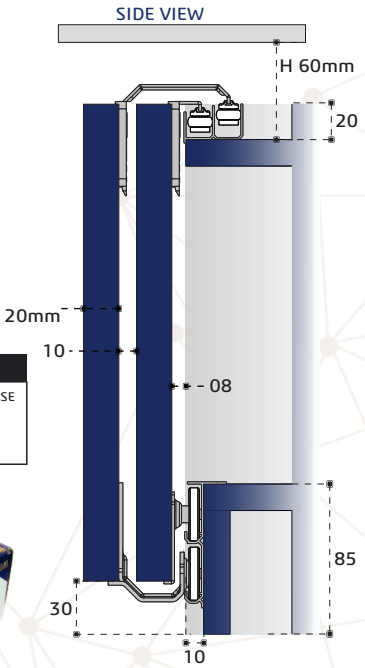

TV SUPPORT

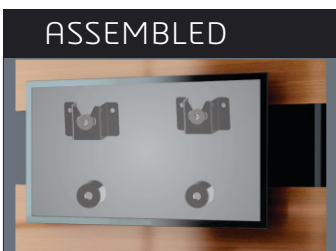
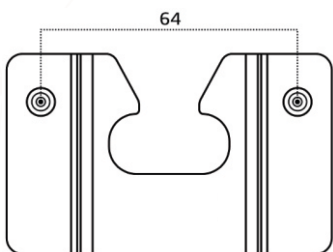

DIFERENTIALS

- FOR TV'S FROM 14" TO 71"
- CARBON STEEL
- SUPPORT UP TO 80kg
- TEMPLATE INCLUDED
- 35mm DISTANCE BETWEEN TV AND WALL

RAILS

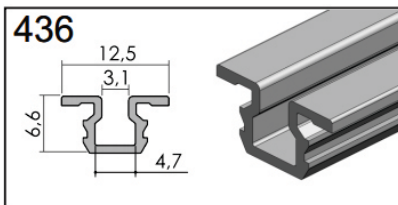

NATURAL SIMPLE
RAIL

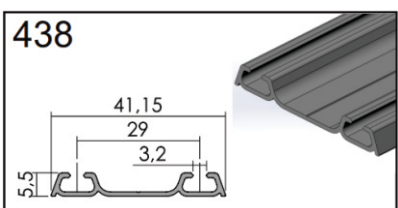

NATURAL OR ANODIZED
DOUBLE 29mm RAIL

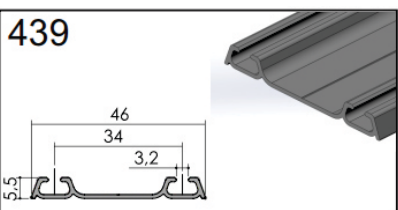

NATURAL OR ANODIZED
DOUBLE 34mm RAIL

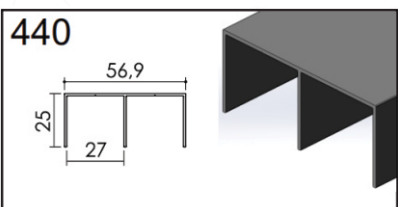

NATURAL OR ANODIZED
TOP RAIL DOUBLE 27MM

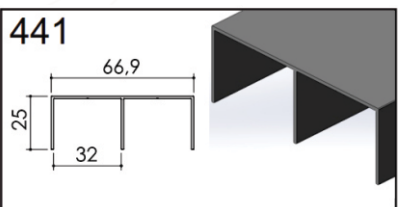

NATURAL OR ANODIZED
TOP RAIL DOUBLE 32MM

HANDLES

474

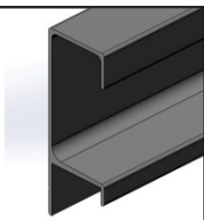
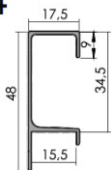

ANODIZED 15MM
DOOR HANDLE

475

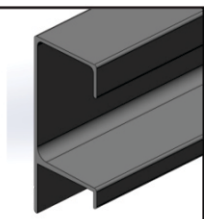

ANODIZED 18MM
DOOR HANDLE

473

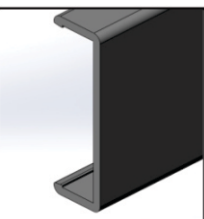
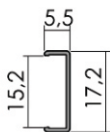

ANODIZED COVER
PROFILE 15MM
DOOR

476

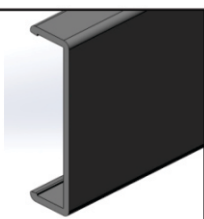
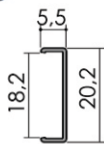

ANODIZED COVER
PROFILE 18MM
DOOR

506

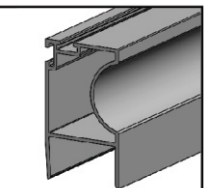
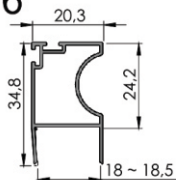

ANODIZED 18MM
DOOR HANDLE



**100% Brazilian
manufacturing**

**Origin
Certificate**

**0% taxes for South
America**

**Quick logistics for latin
America**



www.joelini.com.br

+55 43 3172-4359 | sac@joelini.com.br

facebook.com/joeliniferragens | instagram.com/joelini

R. Arapaçu-Listrado, 260, Pq. Ind. II, Arapongas - PR - CEP 86703-295